



INTERNATIONAL APPLICATION PUBLISHED UNDER THE PATENT COOPERATION TREATY (PCT)

<p>(51) International Patent Classification ⁶ : H04R 1/00</p>	<p>A2</p>	<p>(11) International Publication Number: WO 98/52381 (43) International Publication Date: 19 November 1998 (19.11.98)</p>
<p>(21) International Application Number: PCT/GB98/01362 (22) International Filing Date: 13 May 1998 (13.05.98) (30) Priority Data: 9709959.2 15 May 1997 (15.05.97) GB (71) Applicant (for all designated States except US): NEW TRANSDUCERS LIMITED [GB/GB]; Stonehill, Huntingdon, Cambridgeshire PE18 6E (GB). (72) Inventors; and (75) Inventors/Applicants (for US only): AZIMA, Henry [CA/GB]; 3 Southacre Close, Chaucer Road, Cambridge CB2 2TT (GB). ELLIS, Christien [GB/GB]; Briar Cottage, 3 Barley Road, Great Chishill, Hertfordshire SG8 8SB (GB). HARRIS, Neil [GB/GB]; 9 Davey Crescent, Great Shelford, Cambridge CB2 5JF (GB). (74) Agent: MAGUIRE BOSS; 5 Crown Street, St. Ives, Cambridgeshire PE17 4EB (GB).</p>		<p>(81) Designated States: AL, AM, AT, AU, AZ, BA, BB, BG, BR, BY, CA, CH, CN, CU, CZ, DE, DK, EE, ES, FI, GB, GE, GH, GM, GW, HU, ID, IL, IS, JP, KE, KG, KP, KR, KZ, LC, LK, LR, LS, LT, LU, LV, MD, MG, MK, MN, MW, MX, NO, NZ, PL, PT, RO, RU, SD, SE, SG, SI, SK, SL, TJ, TM, TR, TT, UA, UG, US, UZ, VN, YU, ZW, ARIPO patent (GH, GM, KE, LS, MW, SD, SZ, UG, ZW), Eurasian patent (AM, AZ, BY, KG, KZ, MD, RU, TJ, TM), European patent (AT, BE, CH, CY, DE, DK, ES, FI, FR, GB, GR, IE, IT, LU, MC, NL, PT, SE), OAPI patent (BF, BJ, CF, CG, CI, CM, GA, GN, ML, MR, NE, SN, TD, TG). Published <i>Without international search report and to be republished upon receipt of that report.</i></p>

(54) Title: PANEL-FORM LOUDSPEAKERS

(57) Abstract

A panel-form loudspeaker comprises at least two resonant distributed mode acoustic panels with a single driver provided to excite all the panels such that bending wave energy is efficiently transferred to each of them to excite distributed mode resonance in them to provide acoustic output. There may be two panels one larger than the other - the larger having a lower bending wave stiffness than the smaller. The smaller panel is positioned eccentrically of the larger and the driver eccentrically of the smaller panel. A plurality of smaller panels may be associated with a single larger panel. One embodiment provides a driver mounted to the or each smaller panel which is adhesively attached face to face to the larger panel. Another embodiment provides the or each smaller panel formed within and attached to the larger panel, a driver being attached to the or each smaller panel. The attachment of the panels uses a material forming a controlling compliant coupling. A third embodiment provides the or each smaller panel mounted on one end of an associated coupler passing through and attached to the larger panel, a driver being attached to the other end of the or each coupler. The attachment of the or each coupler to the larger panel uses a material forming a controlling compliance coupling. The or each coupler is tubular in section.

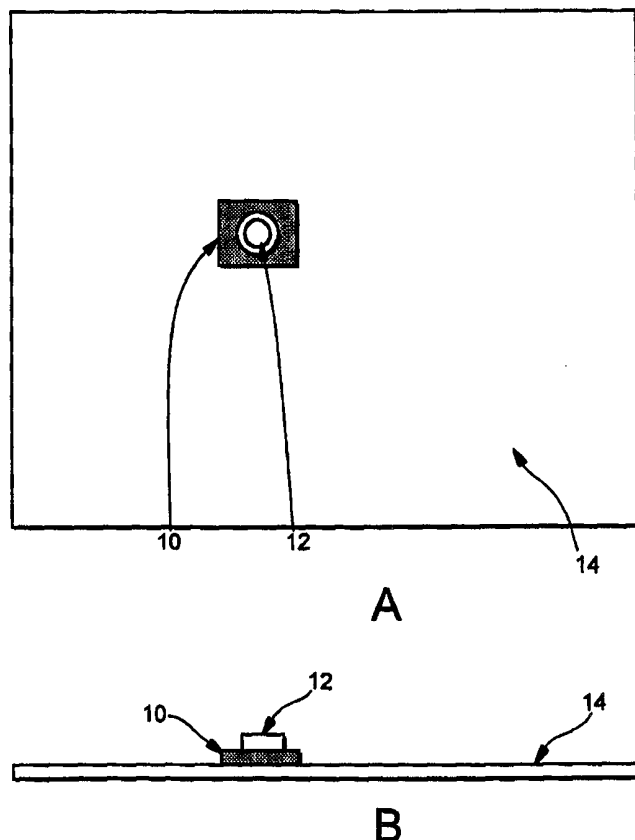

FOR THE PURPOSES OF INFORMATION ONLY

Codes used to identify States party to the PCT on the front pages of pamphlets publishing international applications under the PCT.

AL	Albania	ES	Spain	LS	Lesotho	SI	Slovenia
AM	Armenia	FI	Finland	LT	Lithuania	SK	Slovakia
AT	Austria	FR	France	LU	Luxembourg	SN	Senegal
AU	Australia	GA	Gabon	LV	Latvia	SZ	Swaziland
AZ	Azerbaijan	GB	United Kingdom	MC	Monaco	TD	Chad
BA	Bosnia and Herzegovina	GE	Georgia	MD	Republic of Moldova	TG	Togo
BB	Barbados	GH	Ghana	MG	Madagascar	TJ	Tajikistan
BE	Belgium	GN	Guinea	MK	The former Yugoslav Republic of Macedonia	TM	Turkmenistan
BF	Burkina Faso	GR	Greece	ML	Mali	TR	Turkey
BG	Bulgaria	HU	Hungary	MN	Mongolia	TT	Trinidad and Tobago
BJ	Benin	IE	Ireland	MR	Mauritania	UA	Ukraine
BR	Brazil	IL	Israel	MW	Malawi	UG	Uganda
BY	Belarus	IS	Iceland	MX	Mexico	US	United States of America
CA	Canada	IT	Italy	NE	Niger	UZ	Uzbekistan
CF	Central African Republic	JP	Japan	NL	Netherlands	VN	Viet Nam
CG	Congo	KE	Kenya	NO	Norway	YU	Yugoslavia
CH	Switzerland	KG	Kyrgyzstan	NZ	New Zealand	ZW	Zimbabwe
CI	Côte d'Ivoire	KP	Democratic People's Republic of Korea	PL	Poland		
CM	Cameroon	KR	Republic of Korea	PT	Portugal		
CN	China	KZ	Kazakstan	RO	Romania		
CU	Cuba	LC	Saint Lucia	RU	Russian Federation		
CZ	Czech Republic	LI	Liechtenstein	SD	Sudan		
DE	Germany	LK	Sri Lanka	SE	Sweden		
DK	Denmark	LR	Liberia	SG	Singapore		
EE	Estonia						

5 TITLE: PANEL-FORM LOUDSPEAKERS

10 DESCRIPTION

FIELD OF THE INVENTION

15 The invention relates to panel-form loudspeakers,
and more particularly, but not exclusively, to panel-form
loudspeakers of the kind described in our International
Application WO97/09842 and known as distributed mode
loudspeakers.

20 BACKGROUND ART

 In theory and given the availability of the right
materials, a distributed mode loudspeaker can cover the
full audio range in a single panel. Since the current
state of the art in materials technology precludes such a
25 solution, our International Application WO/9709846
 envisages small distributed mode loudspeaker panel
 suspended in a larger distributed mode loudspeaker panel
 of lower cut-off frequency to produce a wider acoustic

bandwidth loudspeaker. This requires at least two exciters of appropriate type and also requires careful design of the mechanical interface between the two panels.

5 As both panels cover a wide frequency range within their individual capabilities, there will also be a broad frequency range within which the outputs of the two panels may overlap. An electrical cross-over network may therefore be desirable, although it may tend to degrade
10 the sound quality and will add to the manufacturing cost.

An object of the invention is to provide arrangements which alleviate or overcome these difficulties.

GENERAL ASPECTS OF THE INVENTION

15 In one aspect the invention provides a panel-form loudspeaker comprising at least two resonant distributed mode acoustic panels wherein a single driver is provided to excite all of said panels such that bending wave energy is efficiently transferred to each of them to
20 excite distributed mode resonance in them to provide acoustic output.

Desirably, there are two panels and one of said panels may be larger than the other.

The larger of said panels preferably has a lower
25 bending wave stiffness than the smaller.

The smaller of said panels is desirably positioned eccentrically with respect to the larger panel.

The driver is desirably positioned eccentrically

with respect to the smaller of said panels.

In one embodiment a plurality of smaller panels are associated with a single larger panel.

Advantageously, a driver is mounted to the or each
5 smaller panel which is attached to the larger panel, the attachment being such that bending wave energy from the or each driver and its associated smaller panel is efficiently transferred to the larger panel.

Preferably the smaller and larger panels are
10 attached together face to face. The panels may be secured together by means of an adhesive of low mechanical loss.

In another embodiment the or each smaller panel is formed within and attached to the larger panel, a driver being attached to the or each smaller panel.

15 The attachment of the smaller and larger panels may be effected with a material forming a controlling compliant coupling.

In yet another embodiment the or each smaller panel is mounted on one end of an associated coupler passing
20 through and attached to the larger panel, a driver being attached to the or each said coupler.

The driver(s) is preferably attached to the other end of the or each coupler.

The attachment of the or each coupler to the larger
25 panel desirably makes use of a material forming a controlling compliance coupling.

The or each coupler is preferably tubular in section.

BRIEF DESCRIPTION OF THE DRAWINGS

The above aspects, features and advantages of the invention will become apparent from the following description of embodiments of the invention now made with reference to the accompanying drawings, in which:-

Figure 1 shows at A and B respectively rear face and side views of a first panel-form loudspeaker embodying the invention,

Figure 2 is a sectional side view of a second panel-form loudspeaker embodying the invention,

Figure 3 is a sectional side view of a third panel-form loudspeaker embodying the present invention, and

Figure 4 is a rear face view of a modified form of the loudspeakers shown in Figure 1 to 3.

BEST MODES FOR CARRYING OUT THE INVENTION

Figure 1 shows a smaller distributed mode loudspeaker panel (10) driven by an appropriate driver or exciter (12), preferably an electro-dynamic type for greater bandwidth. The smaller panel (10) is attached face to face to a larger distributed mode loudspeaker panel (14) of appropriately lower stiffness and of dimensions appropriate to cover the required lower frequency range. By the choice of the right materials and driver design it can be shown that when the smaller panel (10) is driven it will continue to produce its useful bandwidth superimposed on the lower range frequency output resulting from the larger panel (14) giving a much wider bandwidth.

The smaller distributed mode loudspeaker panel (10) may be attached to the larger one by application of suitable adhesives of low mechanical loss in order to maintain efficient transfer of mechanical energy at low frequencies as well as maintaining good high frequency transmissibility with little loss. Epoxy resin adhesives are suitable for this purpose. The position of attachment of the smaller panel (10) to the larger panel (14) will be chosen in accordance with the distributed mode principle as explained in our International Application WO/97/09842, as will the position of attachment of the exciter (12) to the smaller panel (10).

Figure 2 illustrates another type of panel-form loudspeaker embodying the invention in which a larger, low frequency optimised distributed mode panel (20) is modified by having a smaller, high frequency optimised panel (22) formed in the region of a driver (24). The common driving point of the driver (24) means that both parts or regions of the panel are excited. The smaller, high frequency part or region of the panel is provided by extra stiffening of the local skin region (26) for example by adding bonded carbon fibre, glass fibre or similar high strength material. Alternatively, by adding new higher stiffness skin sections in that region. Depending upon the wave propagation properties of the larger panel (20) a natural balance of power division with frequency may be obtained. Additionally a suitable compliant boundary (28) is incorporated to

differentiate between the high and lower frequency parts of the panel. Control of the compliance frequency dependent damping of the resilient coupling allows the ideal or preferred cross-over point to be determined mechanically together with beneficial control of the damping at the boundary between the two parts of the panel.

Figure 3 illustrates yet another type of panel-form loudspeaker embodying the invention. In the arrangement of Figure 3 a smaller, high frequency, panel (30) is adhesively fixed to one end of a light weight tubular coupler (32). Coupler passes through a larger, low frequency panel (34) and is resiliently attached to it as shown at (36). The resilient attachment of the coupler to the larger panel (34) acts as a mechanical low pass filter to further define the balance of energy between the two panels (30 and 34). It can be seen that the end of the coupler (32) spaced from the high frequency panel (30) is fixed to a driver exciter (38).

Yet another arrangement embodying the invention is illustrated in Figure 4 where a single large resonant distributed mode acoustic panel (50) has associated with it a number of smaller panels (52) each having an associated driver (54). The smaller panels (52) may be associated with the larger panel (50) in the ways described with reference to Figures 1 to 3. That is to say the smaller panel (52) may be adhesively attached face to face to the larger panel (50) and have mounted

thereon its own driver (54). Alternatively, the smaller panels (52) may comprise a number of sections of the larger panel (50) which have been appropriately stiffened and provided with an individual driver (54) - the stiffened sections (52) being coupled to the larger panel in the manner described with reference to Figure 2. Lastly, the smaller panels (52) may comprise panels carried by couplers each associated with an individual driver in the manner described with reference to Figure 3. It will be appreciated that the smaller panels (52) in the arrangement of Figure 4 need not all be associated with the larger panel (50) in the same way. Some may be associated in the way described with reference to Figure 1 whilst others are associated in the way described with reference to Figures 2 and/or 3.

In the described embodiments the driver is in each case attached or coupled to a smaller panel, it will of course be appreciated that the driver may be attached or coupled to the larger of the panels if desired.

INDUSTRIAL APPLICABILITY

The distributed mode loudspeakers described have the benefits of enabling full audio bandwidth from one loudspeaker and reducing the number of drivers required and therefore the cost and complexity of the loudspeakers.

A loudspeaker in accordance with the present invention may be applied to an automobile headliner, with the benefit of a reduced component count, which results

in higher reliability, no need for electrical cross-over components, and reduced manufacturing costs.

CLAIMS

1. A panel-form loudspeaker comprising at least two resonant distributed mode acoustic panels characterised in that a single driver is provided to excite all of said panels such that bending wave energy is efficiently transferred to each of them to excite distributed mode resonance in them to provide acoustic output.
2. A panel-form loudspeaker according to Claim 1, wherein there are two panels and one of said panels is larger than the other.
3. A panel-form loudspeaker according to Claim 2, wherein the larger of said panels has a lower bending wave stiffness than the smaller.
4. A panel-form loudspeaker according to Claim 2 or Claim 3, wherein the smaller of said panels is positioned eccentrically with respect to the larger panel.
5. A panel-form loud speaker as claimed in any one of claims 2 to 4, wherein said driver is positioned eccentrically with respect to the smaller of said panels.
6. A panel-form loudspeaker as claimed in any one of claims 2 to 5, wherein a plurality of smaller panels are associated with a single larger panel.
7. A panel-form loudspeaker as claimed in any one of claims 2 to 6, wherein a driver is mounted to the or each smaller panel which is attached to the larger panel, the attachment being such that bending wave energy from the or each driver and its associated smaller panel is efficiently transferred to the larger panel.

8. A panel-form loudspeaker as claimed in Claim 7, wherein the or each smaller panel is attached to the larger panel face to face.

9. A panel-form loudspeaker as claimed in Claim 7 or
5 Claim 8, wherein the panels are secured together by means of an adhesive of low mechanical loss.

10. A panel-form loudspeaker as claimed in any one of claims 2 to 6, wherein the or each smaller panel is formed within and attached to the larger panel, a driver
10 being attached to the or each smaller panel.

11. A panel-form loudspeaker as claimed in Claim 10, wherein the attachment of the smaller and larger panels is effected with a material forming a controlling compliant coupling.

15 12. A panel-form loudspeaker as claimed in any one of claims 2 to 6, wherein the or each smaller panel is mounted on one end of an associated coupler passing through and attached to the larger panel, a driver being attached to the or each said coupler.

20 13. A panel form loudspeaker as claimed in Claim 12, wherein the driver(s) is attached to the other end of the or each coupler.

14. A panel-form loudspeaker as claimed in Claim 12 or Claim 13, wherein the attachment of the or each coupler
25 to the larger panel makes use of a material forming a controlling compliance coupling.

15. A panel-form loudspeaker as claimed in any one of claims 12 to 14, wherein the or each coupler is tubular

in section.

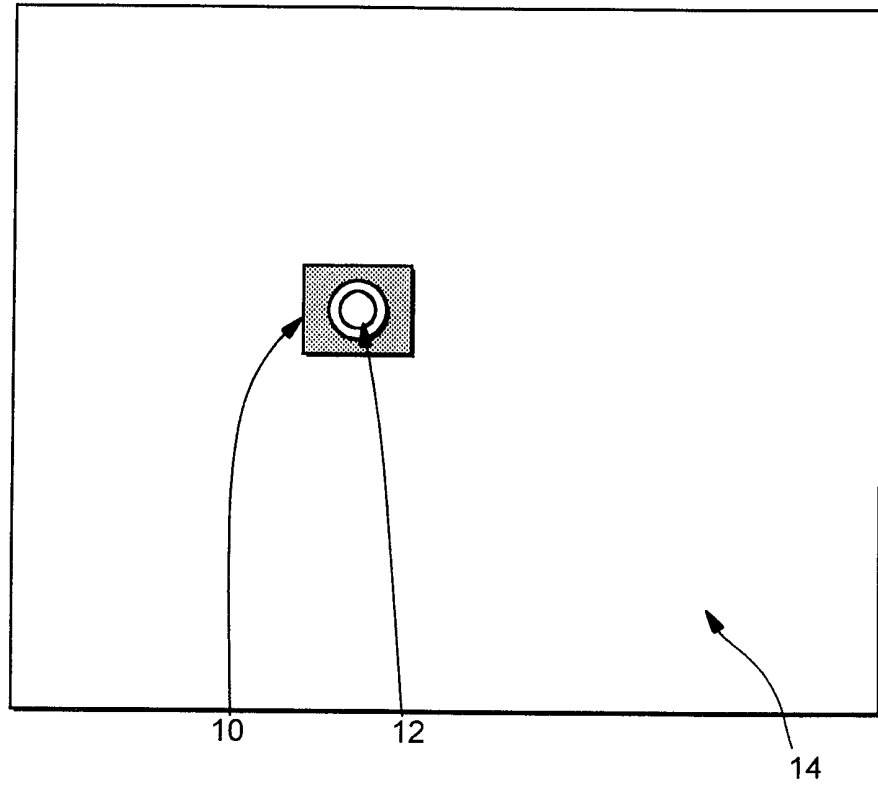

FIG. 1A

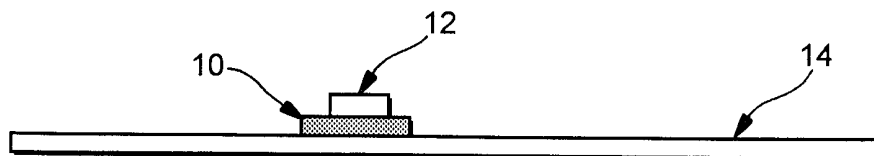

FIG. 1B

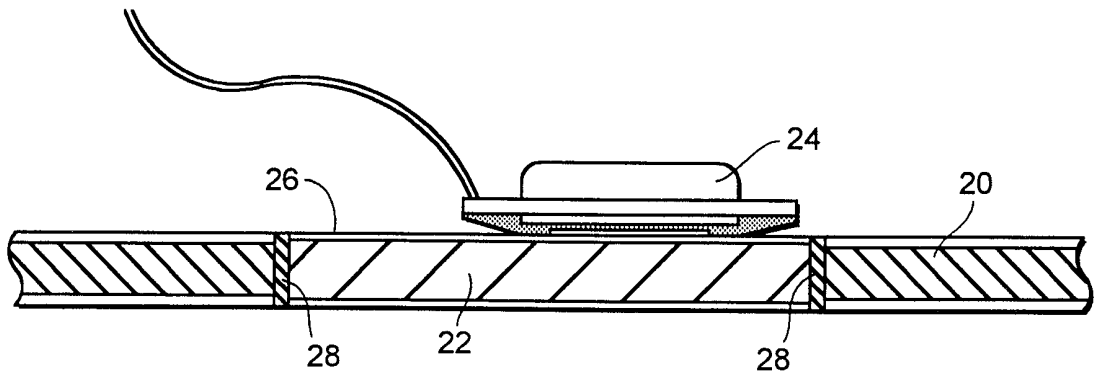

FIG. 2

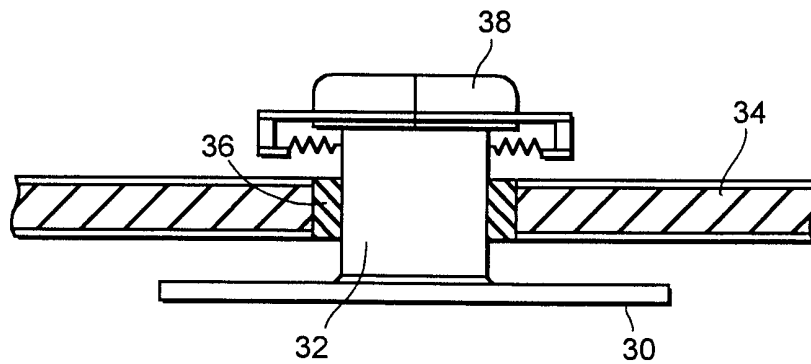

FIG. 3

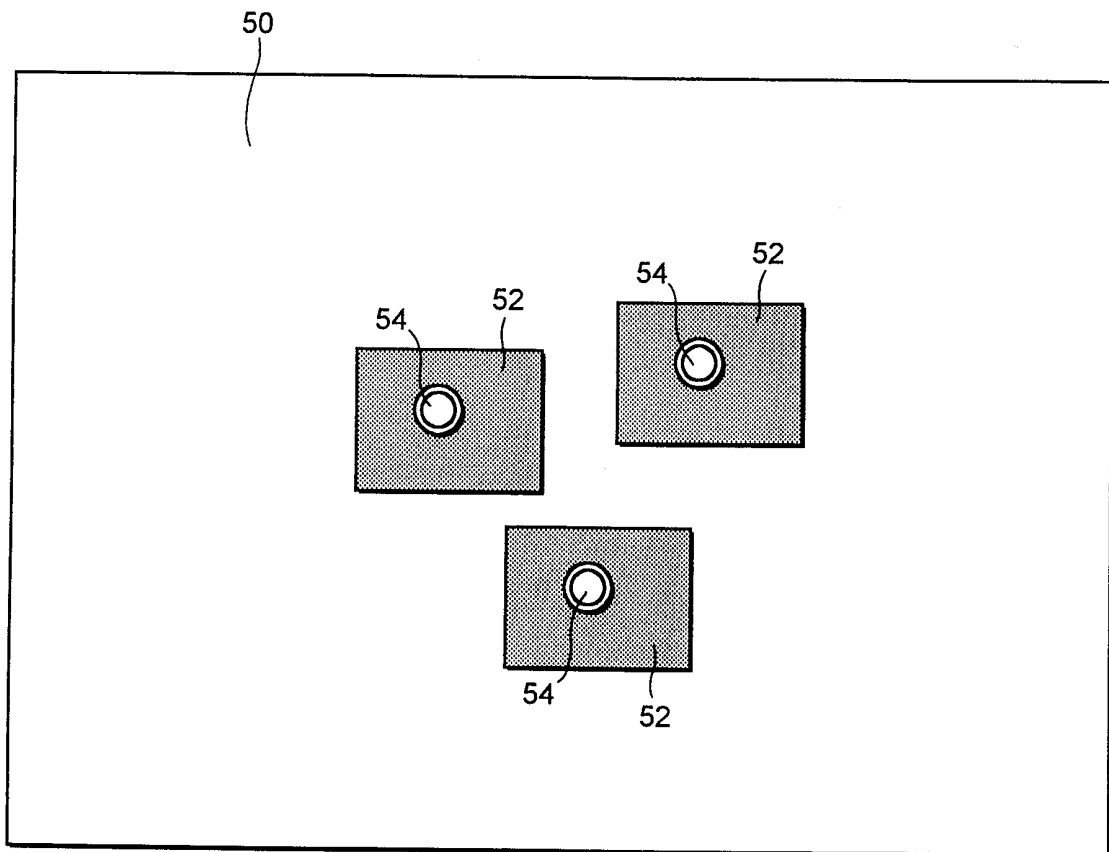

FIG. 4